

3U CompactPCI® board based on 11th Gen Intel® Core™ Processor

Key Features

TP B9x/msd is plug compatible with the popular TP B1x/3sd family allowing transitions for higher performance and longer life deployments.

- 4 and 2-core processor variants available to match application performance and power requirements
- Up to 32 GB DRAM with built in in-band ECC for reliable operation
- Built in I/O interfaces including SATA, USB, Ethernet, graphics, GPIO and serial
- Optional M.2 module for local storage

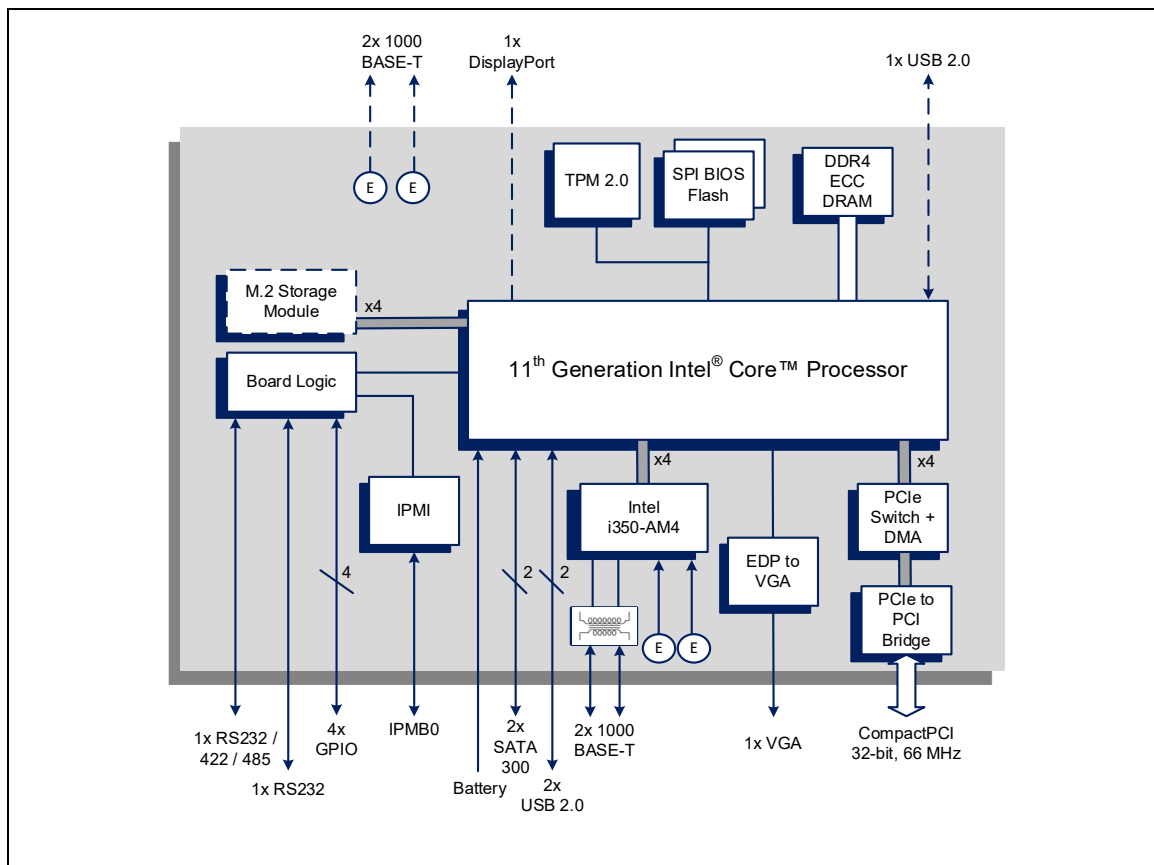

Central Processor

- 11th Gen Intel® Core™ CPU:
 - 4-core Intel® Core™ i7-1185GRE CPU
 - 2-core Intel® Core™ i3-1115GRE CPU
 - Intel® Advanced Vector Extensions AVX-512
 - Intel® Vector Neuro Network Instructions (VNNI)
 - Intel® Iris® Xe (Gen 12) Graphics Engine with up to 96 EUs (i7-1185GRE variant only)

DRAM

- up to 32 Gbytes soldered DDR4-2666 IB ECC (In Band Error Correction Code) DRAM:
 - dual channel architecture
- optional Total Memory Encryption mutually exclusive with IB ECC

Mass Storage Interfaces

- 2x SATA 300 interfaces accessible via J2
- 1x optional M.2 Module:
 - 2242 format module (with option for self-encryption)
 - x4 PCI Express® (PCIe®) interface (M-key)
 - NVMe Express® (NVMe™) logical device interface
 - NVMe 1.3 compatible
 - Write Protect and Opal 2.0 AES-256 available (requires AD 270/001 module)

Ethernet Interfaces

- 2x Ethernet interfaces via RJ45 connectors on front panel supporting:
 - 1000BASE-T or 100BASE-TX
- 2x Ethernet interfaces via J2 supporting:
 - 1000BASE-T or 100BASE-TX
- implemented by an Intel® i350-AM4 Ethernet controller via a 1 x4 PCI Express® port

Graphics Interface

- DisplayPort® 1.4 graphics interface via full-size connector on front panel:
 - resolutions up to 3840 x 2160
- VGA graphics interface via J2:
 - resolutions up to 1920 x 1200
- support for Microsoft® DirectX 12 on Windows® and OpenGL 4.5 on Linux®

Serial Interfaces

- 2x serial interfaces accessible via J2:
 - 1x RS232 interface supporting Tx and Rx
 - 1x RS232 interface supporting Tx, Rx, RI, CTS, RTS, DSR, DTR and DCD or 1 x RS422/RS485 supporting Tx and Rx
- 16550 compatible UARTs

Other Peripheral Interfaces

- PC-compatible Real Time Clock
- watchdog timer; 32-bit Long Duration Timer with processor interrupt ability
- 1x USB interface accessed via front panel:
 - 1x USB 2.0 interface via Type A connector
- 2x USB 2.0 interfaces via J2
- 4x GPIO signals via J2
- external battery supply for the RTC
- CPU temperature monitor; board temperature monitor; voltages monitor:
 - all accessible via IPMI

IPMI

- PICMG 2.9 R1.0 (System Management Spec.):
 - implements the IPMB0 interface
- on-board Baseboard Management Controller
- supports 8 Kbytes of non-volatile memory

CompactPCI Interface

- universal signalling support, compliant with PICMG® 2.1 R2.0; 3.3 V or 5 V signalling levels
- 33/66 MHz; 32-bit interface via J1
- PCI Express link from processor via PCIe-PCI bridge for off-board accesses:
 - DMA hardware support included
- operates as a System Slot controller (supporting up to 7 peripheral slots) or operates in a Peripheral Slot:
 - supports hot-swapping peripheral boards
 - PICMG 2.1 R2.0 Hot Swap Specification
- user option to disable CompactPCI® interface (Satellite Mode):
 - receives power from CompactPCI bus
 - board can be hot swapped

Software Support

- support for Linux® and Windows®. Contact CCT for further options

Firmware Support

- dual 32 Mbyte BIOS SPI Flash EPROMs
- UEFI boot firmware (BIOS):
 - UEFI 2.7 support
 - implements Secure Boot
- implements Intel® Boot Guard
- optional Fast Boot solution using the Intel® Firmware Support Package (FSP)
- LAN boot firmware included

Optional Built-In Test (BIT) Support

- Power-on BIT (PBIT), Initiated BIT (IBIT), Continuous BIT (CBIT)

Board Security Features

- Trusted Platform Module (TPM 2.0) fitted
- option for Sanitization Utility Software Package
- option for proprietary board-level security features
- supports ROP Attack Prevention and Advanced Crypto Key Protection

Safety

- PCB (PWB) manufactured with flammability rating of UL94V-0

Electrical Specification

- typical current consumption (4-core processor with 16 Gbytes DRAM):
 - +5 V @ 2.2 A
 - +3.3 V @ 3.1 A
- voltages +5%/-3%
- +12 V and -12 V not required

Environmental Specification

- operating temperatures:
 - 0°C to +55°C (N-Series)
 - -25°C to +70°C (E-Series)
 - -40°C to +85°C (K-Series)
- non-operating temperature: -40°C to +85°C
- 5% to 95% Relative Humidity, non-condensing

Mechanical Specification

- 3U form-factor:
 - 3.9-inches x 6.3-inches (100 mm x 160 mm)
- single slot (0.8")
- connectors: IEC-1076-4-101 for J1-J2
- shock: 20 g, 11 ms, ½ sine
- vibration: 5 Hz-2000 Hz at 2 g, 0.38 mm peak displacement

Legacy Computing Board Compatibility

- rear I/O compatible with the popular TP B1x/3sd