

## Rugged Conduction-Cooled VME board based on Intel® Xeon® processor

### Key Features

VP B7x/msd-RC is a rugged conduction-cooled VMEbus board based on a high performance 6-core Intel® Xeon® processor E-2176M. It is designed for high security, long life-cycle applications using the latest operating systems.

- Six-core processor and up to 32 Gbytes DDR4 DRAM for high performance applications
- Dual PMC/XMC sites for local expansion
- Wide variety of I/O interfaces including SATA, USB, Ethernet, graphics and serial
- Direct attached storage options suitable for operating system, application and data use
- Board support packages for Linux®, Windows® 10 and VxWorks® 7
- Option to exclude VMEbus interface is available

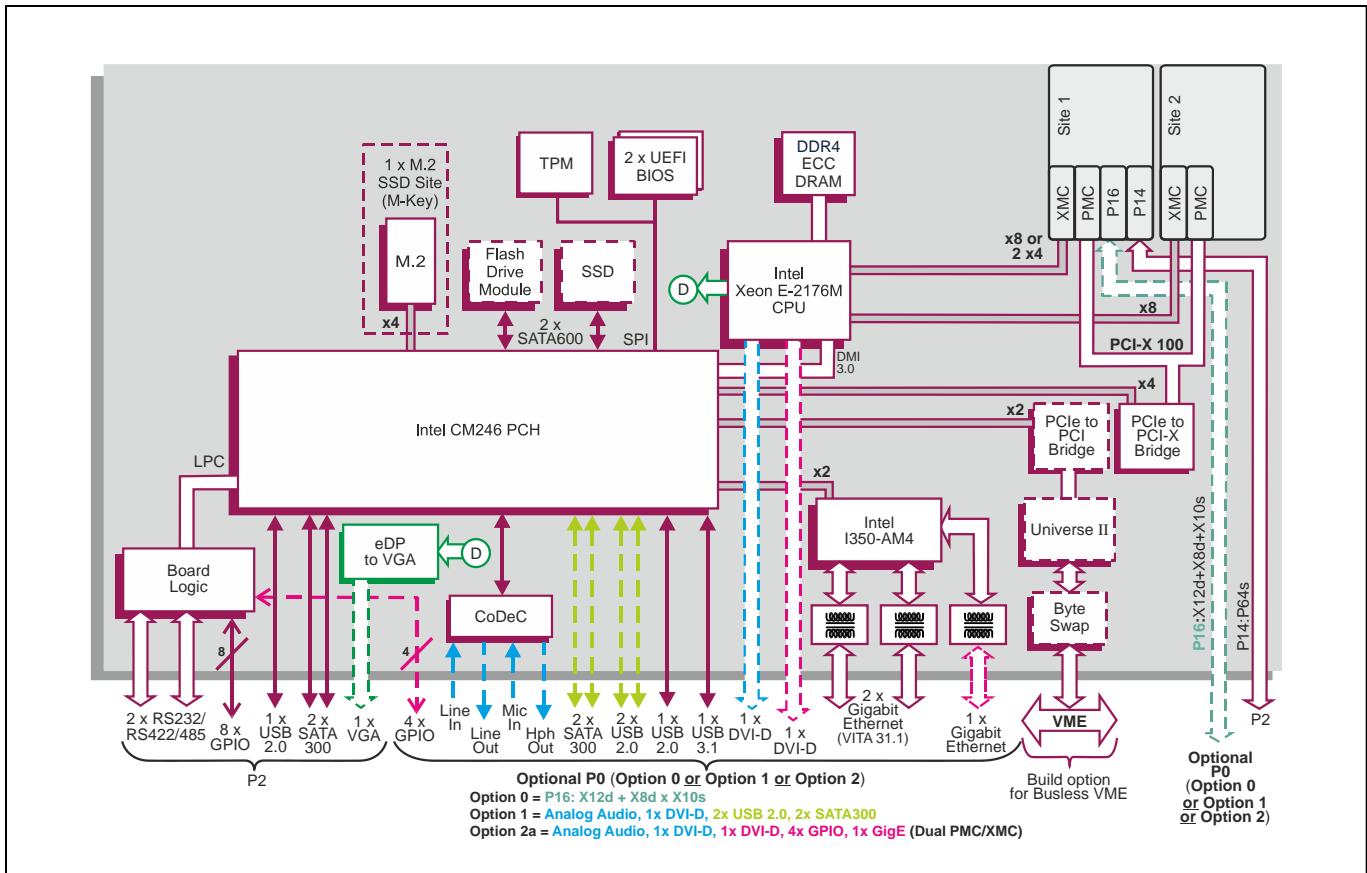

## VME Embedded Computer Board

- rugged conduction-cooled 6U VME computing board utilizing an Intel® Xeon® processor (coded Coffee Lake-H)
- dual XMC sites
- air-cooled (N, E, K-Series) versions:
  - see VP B7x/msd datasheet

## Central Processor

- 6-core Intel® Xeon® processor E-2176M:
  - 12 Mbytes Smart Cache, 2.2 GHz (35W)
  - Intel® UHD Graphics 630
- utilizes the Intel® CM246 Platform Controller Hub

## DRAM

- 16 or 32 Gbytes soldered DDR4 ECC DRAM:
  - single bit error correction
  - dual channel architecture
- accessible from processor or VME bus

## PMC/XMC Interfaces

- dual PMC/XMC interfaces
- PMC/XMC I/O site 1:
  - PMC P14 rear I/O (P64s) via P2
  - XMC P16 rear I/O (X12d+X8d+X10s) via optional P0 (build option 0)
- PMC PCI/PCI-X interfaces:
  - 32/64-bit, 33/66 MHz PCI bus
  - 64-bit PCI-X bus up to 100 MHz
  - 5V and 3.3V signaling
- XMC PCI Express interfaces:
  - both support x8 PCI Express (Gen 1, Gen 2)
  - XMC site 1 can also support 2 x4 PCI Express
  - both powered from 5V supply

## Ethernet Interfaces

- up to 3 x Gigabit Ethernet interfaces:
  - implemented by an Intel® I350-AM4 LAN controller via a x2 PCI Express® port (Gen 2)
- 2 x Gigabit Ethernet interfaces via optional P0:
  - utilizes VITA 31.1 (Gigabit Ethernet for VME64x backplanes)
- 1 x Gigabit Ethernet interface as a build option:
  - via P0 (build option 2a only)
  - on-board magnetics (50V isolation via P0)

## Mass Storage Interfaces

- up to 4 x external SATA300 interfaces:
  - 2 x SATA via P2
  - 2 x SATA (build option 1) via optional P0
- 1 x M.2 SSD site on-board supporting:
  - Type 2242 device only
  - x4 PCIe interface (M-key)
  - NVMe Express® (NVMe™) logical device interface
  - NVMe 1.3 compatible
  - 2242 device can be fitted simultaneously with PMC/XMC module fitted to PMC/XMC site 2
- 2 x SATA600 interfaces for optional on-board:
  - SATA Flash Drive Module
  - 2.5-inch SATA drive (disables PMC/XMC Site 2)

## Serial Interfaces

- 2 x serial channel interfaces: 2 x RS232/422/485 accessed via P2
- 16550 compatible UARTs

## Stereo Audio

- Intel® High Definition Audio interface with CoDeC (build options 1 & 2) via optional P0:
  - line level stereo input and output
  - line level microphone input
  - headphone output

## Graphics Interfaces

- 1 x DVI-D interface (build option 1) or 2 x DVI-D interfaces (build option 2a) via optional P0:
  - up to 1920 x 1200 @ 16M colors
- 1 x VGA interface (build option) via P2:
  - up to 1920 x 1200 @ 16M colors
  - embedded DisplayPort to VGA converter
- support for Microsoft® DirectX 12, OpenGL 4.5 under Windows® and Linux® and OpenCL 2.1

## Other Peripheral Interfaces

- PC Real Time Clock
- watchdog timer; 32-bit Long Duration Timer with processor interrupt ability; chipset timer
- 1 x USB 2.0 via P2
- up to 4 x USB ports accessed via optional P0:
  - 1 x USB 2.0 port and 1 x USB 3.1 (Gen 1) port
  - 2 x USB 2.0 ports (build option 1)
- 8 x GPIO signals via P2 plus 4 x GPIO signals (build option 2a) via optional P0:
  - supports processor interrupt capability
- Write Protect (build option 2a) and External Reset (build option 2a) via optional P0

## Flash EPROM

- 32 Mbytes of BIOS Flash EPROM, dual devices:
  - main/backup device enabled via switch

## Software Support

- support for Linux®, Windows® and VxWorks®

## Board Security Packages

- Trusted Platform Module (TPM 2.0)
- option for Sanitization Utility Software Package
- option for proprietary board-level security features

## Firmware Support

- UEFI 2.7 boot firmware (BIOS):
  - implements Secure Boot
- implements Intel® Boot Guard
- optional Fast Boot solution using the Intel® Firmware Support Package (FSP)
- LAN boot firmware included

## Optional Built-In Test (BIT) Support

- Power-on BIT (PBIT), Initiated BIT (IBIT), Continuous BIT (CBIT)

## Safety

- PCB (PWB) manufactured with flammability rating of UL94V-0

## VME Interface

- P1 and P2 connectors compatible with VME64x
- implemented using IDT® Universe™ II device
- VME Master/Slave
- A32/A24/A16/D64/D32/D16/D8(E0)/MBLT
- fast hardware byte swapping
- auto system controller detect
- full interrupter / interrupt handler support
- bus error interrupt support
- build option for busless VME interface:
  - SYSRESET, SYSFAIL, ACFAIL, GAX
  - VMEbus daisy chain

## Electrical Specification (Estimated)

- typical current figure for processor (35W) with 16 Gbytes DRAM:
  - +5V @ 5.9A
  - +12V @ 0.0A; -12V @ 0.0A; 3.3V not required
  - +12V and -12V routed to both PMC/XMC sites

## Environmental Specification

- operating temperature (at card edge) based upon processor's performance/power factory build option:
  - VITA 47 Class CC4, -40°C to +85°C
  - conduction-cooled
- non-operating temperature:
  - VITA 47 Class C4, -55°C to +105°C
- operating altitude:
  - -1,000 to 50,000 feet (-305 to 15,240 meters)
- 5% to 95% Relative Humidity, non-condensing

## Mechanical Specification

- 6U form-factor
- single slot, width 0.8 inch (20.3mm)
- utilizes 160-way connectors for P1 and P2
- optional P0 connector
- operating mechanical:
  - shock - VITA 47 Class OS2, 40g
  - random vibration - VITA 47 Class V3, 0.1g<sup>2</sup>/Hz

## Legacy Board Compatibility

- VP B7x/msd-RC rear plug compatibility with the popular VP B1x/msd-RC and VP 92x/x1x-RC families