

## Rugged Processor XMC module based on 6<sup>th</sup> Generation Intel® Processor

### Key Features

XP B5x/msd-RC is based on a 6<sup>th</sup> generation Intel® processor for long life-cycle deployments. When fitted on a suitable carrier, the combination can provide excellent size, weight and power metrics for rugged and extended temperature operating environments.

- 6<sup>th</sup> generation Intel processor mated with ECC memory
- Built in Solid State Drive for reliable storage
- Wide range of I/O interfaces available on XMC connectors
- Air-cooled versions available
- Support for Linux®, Windows® and VxWorks®

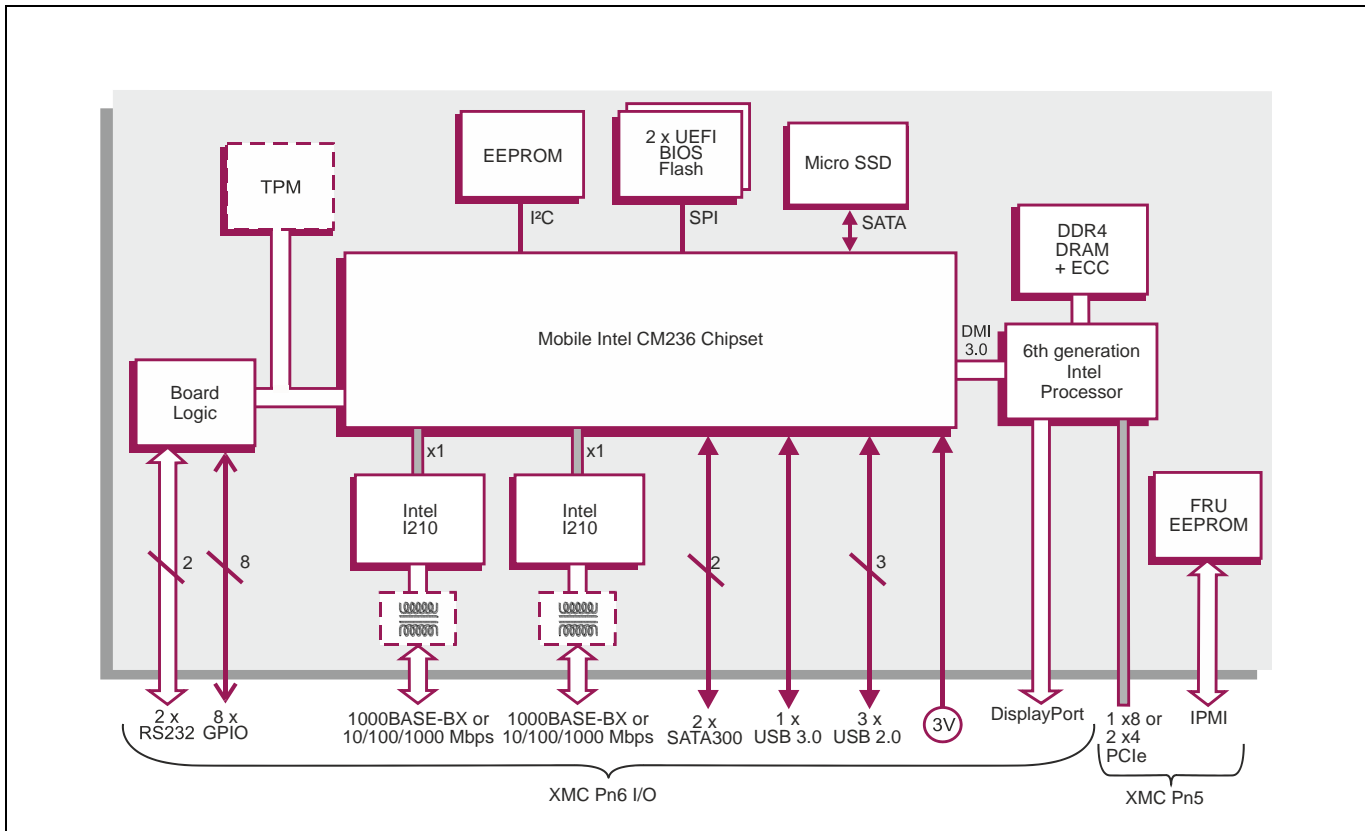

## Rugged Processor XMC Module

- utilizes 6<sup>th</sup> generation Intel® processor
- XMC Pn6 and Pn5 connectors (build option), select:
  - VITA 42 XMC (color black)
  - VITA 61 XMC 2.0 (color white)
- configurable PCI Express® interface via Pn5
- range of I/O interfaces via Pn6
- conduction-cooled to ANSI/VITA 20-2001 (R2005)
- conformally coated
- air-cooled variants available:
  - see separate XP B5x/msd datasheet

## Central Processor

- 4-core Intel® Xeon® processor E3-1505L v5:
  - 8 Mbytes Smart Cache, 2.0 GHz
  - Intel® HD Graphics P530
- 2-core Intel® Core™ i3-6102E processor:
  - 3 Mbytes Last Level Cache, 1.9 GHz
  - Intel® HD Graphics 530
- utilizes the Mobile Intel® CM236 Chipset

## DRAM

- up to 16 Gbytes soldered DDR4 DRAM:
  - dual channel architecture
  - bus speed 2133MHz
- accessible from local processor and base board

## XMC Interface

- configurable PCI Express (PCIe®) interface via XMC Pn5 connector supports:
  - 1 x8 or 2 x4 PCIe ports
  - PCIe Gen 1, Gen 2 and Gen 3
- XMC Pn5 connector type (build option) determines the maximum PCIe operational speed:
  - up to Gen 2, VITA 42 connector
  - up to Gen 3, VITA 61 connector
- supports Root Complex operation
- supports IPMI Interface

## Gigabit Ethernet Interfaces

- 2 x Gigabit Ethernet interfaces via Pn6
- factory build option for 2 x 1000BASE-BX ports
- alternative factory build option for 2 x 10/100/1000 Mbps Ethernet ports:
  - 10BASE-T, 100BASE-TX, 1000BASE-T
  - optional on-board magnetics
- support for IEEE 1588 precision clock
- implemented by two Intel® Ethernet Controller I210 devices via x1 PCIe ports

## Mass Storage Interfaces

- 2 x SATA300 interfaces via XMC Pn6 connector
- 64 Gbytes soldered Micro SSD

## Serial Interfaces

- 2 x RS232 serial ports:
  - port 1 supports Tx, Rx, RTS, CTS, DSR, DCD, DTR, RI via rear Pn6
  - port 3 supports Tx, Rx, RTS, CTS via Pn6
- 16550 compatible UARTs

## Graphics Interface

- DisplayPort™ interface:
  - 4096 x 2034 @ 60Hz
- accessible via Pn6
- support for Microsoft® DirectX 11.1 on Windows®
- support for OpenGL 4.4 on Microsoft® Windows® and Linux®

## Other Peripheral Interfaces

- watchdog timer, 1 x 32-bit Long Duration Timer
- PC Real-Time Clock (no on-board battery):
  - VBAT can be supplied via Pn6
- 4 x USB ports via Pn6:
  - 1 x USB 3.0 port
  - 3 x USB 2.0 ports
- 8 x GPIO signals via Pn6:
  - processor interrupt capability

## Flash EPROM

- dual 16 Mbytes of BIOS Flash EEPROM

## Board Security Features

- option for Trusted Platform Module (TPM 2.0)
- option for Sanitization Utility Software Package

## Firmware Support

- UEFI 2.4 boot firmware (BIOS) :
  - UEFI 2.4 support
  - includes Compatibility Support Module
  - implements Secure Boot
- LAN boot firmware included

## Software Support

- support for Linux®, Windows® and VxWorks®

## Optional Built-In Test (BIT) Support

- Power-on BIT (PBIT), Initiated BIT (IBIT), Continuous BIT (CBIT)

## Electrical Specification

- typical current figure (1.9 GHz, 8 Gbytes DRAM):
  - +5V @ 4.0A
- +5V VPWR, voltage +5% / -5%
- +12V VPWR is not supported
- supports board power management, under software control

## Safety

- PCB (PWB) manufactured with flammability rating of UL94V-0

## Environmental Specification

- operating temperature:
  - VITA 47 Class CC4, -40°C to +85°C
  - conduction-cooled
- non-operating temperature:
  - VITA 47 Class C4, -55°C to +105°C
- operating altitude:
  - -1,000 to 50,000 feet (-305 to 15,240 meters)
- 5% to 95% Relative Humidity, non-condensing

## Mechanical Specification

- single-width CMC (Common Mezzanine Card) IEEE 1386 form factor: (74mm x 149mm)
- 10mm height stack module