

# E430RQ8

## 4.3" Qualcomm® Snapdragon™ 660 Rugged handheld PDA

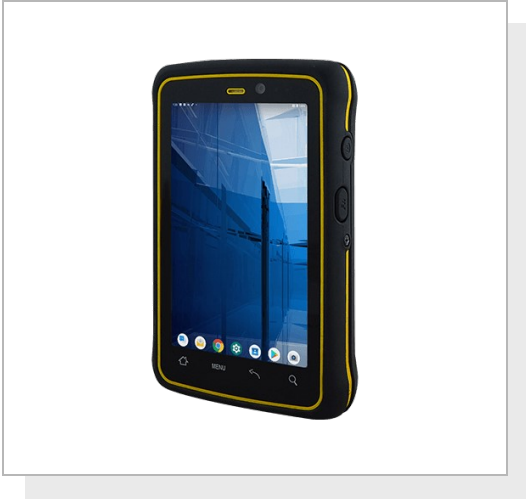

### KEY FEATURES

- Qualcomm® Snapdragon™ 660 (Octa-core 2.2 GHz), Rugged handheld PDA
- 4.3" 800 x 480 Panel with direct optical bonding
- Optional 1D/2D Barcode Reader for data collection
- IP65 waterproof and dustproof
- Supports Android 9.0, android pocket computer



### SPECIFICATIONS

Display			
Resolution	800x480	Size	4.3 inches
Contrast Ratio	800:1	Panel Brightness	400 nits
View Angles	80,80,80,80	Type	Projected Capacitive Multi Touch
System Specification			
Processor	Qualcomm® Snapdragon™ 660 (Octa-Core 2.2 GHz)	Memory	3GB
Storage	32GB	Operating System	Android 9.0
WLAN	Support	BT	Support
RFID	NFC (Read / Write, Peer to Peer mode) (Optional)	Sensors	Ambient Light Sensor, E-Compass, Gyro, Acceleration Sensors
Camera			
Front Camera	8MP Camera	Rear Camera	13MP Camera with LED Auxiliary Light (Auto Focus)
Mechanical			
Dimension	132.57 x 81.87 x 27.4 mm	Weight	260g
IO Ports			
USB Port	1 x USB 3.0 Type C OTG (support charging)	SD Card Slot	1 x Micro SD Card Slot
Audio	1 x Built-in Mic 1 x Speaker	Indicator	1 x LED Indicators (Power, Battery)
Docking Connector	1 x Docking Connector		
Environment			
Operating Humidity	5% to 95% RH, Non-Condensing	Operating Temperature	-20°C to 60°C
Storage Temperature	-30°C to 70°C	Shock	MIL-STD-810G Method 516.6 Procedure I
Vibration	MIL-STD-810G Method 514.6 Procedure I	IP rating	IP65
Drop	MIL-STD-810G Method 516.6, 5 ft		
Certification			
Certification	CE, FCC		
Control			

<b>Button</b>	1 x Volume +/- , 1 x Power Button, 1 x Function Button, 4 Capacitive Button (1 x Home, 1 x Menu, 1 x Esc, 1 x Search)		
<b>Power</b>			
<b>Battery</b>	3.7V 3900mAh	<b>Battery Operating Time</b>	20Hr
<b>Power Rating</b>	5V	<b>Adapter</b>	5V 1A Adapter with USB TypeC
<b>Security Function</b>			
<b>SOTI MobiControl</b>	SOTI MobiControl Compliance		
<b>Accessory</b>			
<b>Accessory</b>	Universal Adapter USB Type-C Cable Battery Hand Strap	<b>Optional Accessory</b>	Charging Dock 2 bay Charging Dock 6 bay Battery Charging Dock 2 bay Battery Charging Dock 6 bay Vehicle Charging Dock Battery Leather Holster Lanyard Micro SD Card
<b>Barcode Scanner</b>			
<b>Barcode Scanner</b>	1D/2D Barcode Reader (Optional)		

**DIMENSIONS** UNIT:MM

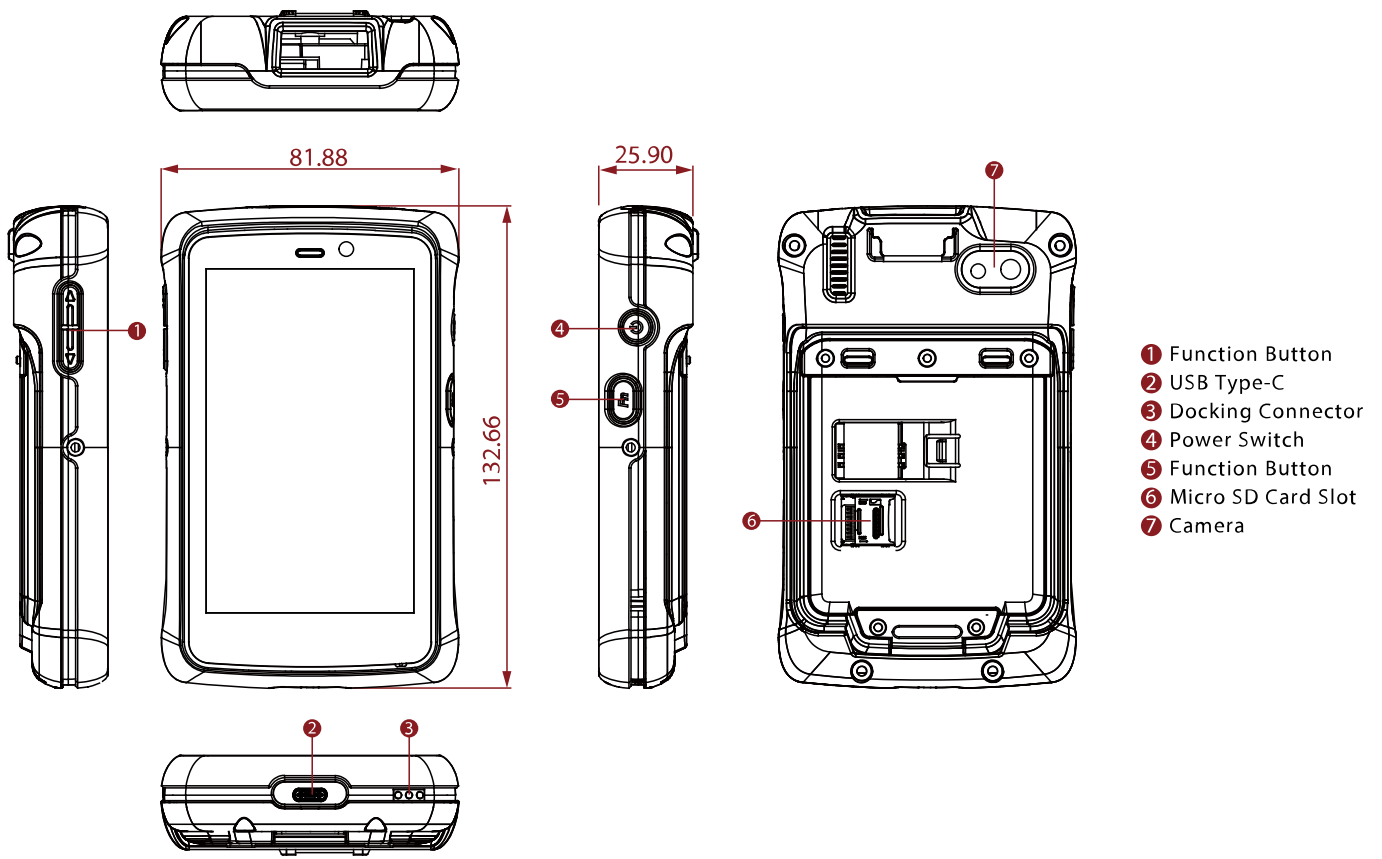

## NOTE

1. Total usable memory will be less dependent upon actual system configuration.
2. SOTI is available upon request.
3. Length measurements do not include protrusions.
4. The drop test with a high-capacity battery must come with a hand strap.
5. Measured at dimming LCD brightness. Varies depending on the usage conditions, or when an external device is attached.
6. Accessories and Integrated Options may vary depending on your configuration.
7. This is a simplified drawing and some components are not marked in detail.
8. The product shown in this datasheet is a standard model. For diagrams that contain customized or optional I/O, please contact the Winmate Sales Team for more information.